

Contents

American National Standards

Call for Comment on Standards Proposals	2
Call for Comment Contact Information	5
Call for Members (ANS Consensus Bodies)	7
Final Actions	8
Project Initiation Notification System (PINS)	10

International Standards

ISO Draft Standards	17
ISO and IEC Newly Published Standards	18
Proposed Foreign Government Regulations	20
Information Concerning	21

American National Standards

Call for comment on proposals listed

This section solicits public comments on proposed draft new American National Standards, including the national adoption of ISO and IEC standards as American National Standards, and on proposals to revise, reaffirm or withdraw approval of existing American National Standards. A draft standard is listed in this section under the ANSI-accredited standards developer (ASD) that sponsors it and from whom a copy may be obtained. Comments in connection with a draft American National Standard must be submitted in writing to the ASD no later than the last day of the comment period specified herein. Such comments shall be specific to the section(s) of the standard under review and include sufficient detail so as to enable the reader to understand the commenter's position, concerns and suggested alternative language, if appropriate. Please note that the ANSI Executive Standards Council (ExSC) has determined that an ASD has the right to require that interested parties submit public review comments electronically, in accordance with the developer's procedures.

Ordering Instructions for "Call-for-Comment" Listings

1. Order from the organization indicated for the specific proposal.
2. Use the full identification in your order, including the BSR prefix; for example, Electric Fuses BSR/SAE J554.
3. Include remittance with all orders.
4. BSR proposals will not be available after the deadline of call for comment.

Comments should be addressed to the organization indicated, with a copy to the Board of Standards Review, American National Standards Institute, 25 West 43rd Street, New York, NY 10036. Fax: 212-840-2298; e-mail: psa@ansi.org

Comment Deadline: June 20, 2010

NSF (NSF International)

Revisions

BSR/NSF 245-201x (i4), Wastewater treatment systems - Nitrogen reduction (revision of ANSI/NSF 245-2007)

Issue 4 - Updates the table in Section 8.3.3, Analysis, which requires treated effluent analysis for TKN, NO₂, and NO₃. However, this same section requires the raw influent to be analyzed for TKN and not NO₂ or NO₃, thus not meeting the definition of total nitrogen. The result is a potential discrepancy in calculating the total nitrogen reduction performance.

[Click here to see these changes in full, or look at the end of "Standards Action."](#)

Send comments (with copy to BSR) to: Mindy Costello, (734) 827-6819, mcostello@nsf.org

UL (Underwriters Laboratories, Inc.)

Revisions

BSR/UL 1685-201x, Standard for Safety for Vertical-Tray Fire-Propagation and Smoke-Release Test for Electrical and Optical-Fiber Cables (revision of ANSI/UL 1685-2007)

Clarifies burner position requirements.

[Click here to see these changes in full, or look at the end of "Standards Action."](#)

Send comments (with copy to BSR) to: Camille Alma, (631) 271-6200, Camille.A.Alma@us.ul.com

Comment Deadline: July 5, 2010

ASABE (American Society of Agricultural and Biological Engineers)

New Standards

BSR/ASAE S418.1-201x, Dimensions for Cylindrical Hydraulic Couplers for Lawn and Garden Tractors (new standard)

Establishes interface dimensions of cylindrical hydraulic couplers frequently used by the equipment industry to connect hydraulic remote cylinders and other hydraulic devices to lawn and garden tractors. Permits interchangeable use of remote cylinders and other hydraulic devices on different makes of tractors when designed for this use.

Single copy price: \$48.00

Obtain an electronic copy from: vangilder@asabe.org

Order from: Carla VanGilder, (269) 932-7015, vangilder@asabe.org

Send comments (with copy to BSR) to: Same

AWWA (American Water Works Association)

New Standards

BSR/AWWA C516-201x, Large Diameter Rubber-Seated Butterfly Valves Sizes 78 in. (2,000 mm) and Larger (new standard)

Establishes minimum requirements for rubber-seated butterfly valve assemblies, 78 in. (2,000 mm) diameter and larger with flanged ends for fresh water having a pH range from 6 to 12 and a temperature range from 33 - 125 F (0.6 - 52 C) and suitable for a maximum steady-state fluid working pressure of 150 psig (1,034 kPa [gauge]), a maximum steady-state differential pressure of 150 psi (1034 kPa), and a maximum full open fluid velocity of 16 ft/sec (4.9 m/sec) based on nominal valve size.

Single copy price: \$20.00

Obtain an electronic copy from: llobb@awwa.org

Order from: Paul Olson, (303) 347-6178, polson@awwa.org

Send comments (with copy to BSR) to: Same

Revisions

BSR/AWWA C105/A21.5-201x, Polyethylene Encasement for Ductile-Iron Pipe Systems (revision of ANSI/AWWA C105/A21.5-2005)

Describes materials and installation procedures for polyethylene encasement to be applied to underground installations of ductile-iron pipe. This standard also may be used for polyethylene encasement of fittings, valves, and other appurtenances to ductile-iron pipe systems.

Single copy price: \$20.00

Obtain an electronic copy from: llobb@awwa.org

Order from: Paul Olson, (303) 347-6178, polson@awwa.org

Send comments (with copy to BSR) to: Same

EASA (Electrical Apparatus Service Association)

Revisions

BSR/EASA AR100-201x, Recommended Practice for the Repair of Electrical Apparatus (revision of ANSI/EASA AR100-2006)

Describes recordkeeping, tests, analysis, and general guidelines for the repair of rotating electrical apparatus, including generators and motors.

Single copy price: \$24.00

Obtain an electronic copy from: easainfo@easa.com

Order from: EASA, easainfo@easa.com

Send comments (with copy to BSR) to: Thomas Bishop, (314) 993-2220, tbishop@easa.com

IAM (The International Association of Movers)

New Standards

BSR/HHGFAA NCC 2008-001-201x, Numeric Codification of Contents for Electronic Inventories and Manifests of Household Goods and Personal Effects Shipments (new standard)

Develops an open and voluntary electronic standard for international household goods & personal effects shipments originating in the United States or having the United States as its destination, or a shipment moving from one country to another, controlled and / or managed by a company using U.S. standards. The standard will define the minimum transaction header data, and provide for the numerical codification of items and exceptions that constitute a shipment. The standard will not be vendor, software or hardware specific, providing freedom of movement and choice for the customers of hand-held readers, inventory software, and other related hardware and software.

Single copy price: \$10.00

Obtain an electronic copy from: brian.limperopulos@iamovers.org

Order from: Brian Limperopulos, (703) 317-9950, brian.limperopulos@iamovers.org

Send comments (with copy to BSR) to: Same

NEMA (ASC C29) (National Electrical Manufacturers Association)

Reaffirmations

BSR C29.9-1983 (R201x), Wet-Process Porcelain Insulators - Apparatus, Post Type (reaffirmation of ANSI C29.9-1983 (R2002))

Covers outdoor high-voltage post-type apparatus insulators made of wet-process porcelain and used in the transmission and distribution of electrical energy.

Single copy price: \$40.00

Obtain an electronic copy from: NEMA
<http://www.nema.org/stds/c29-9.cfm>

Order from: Global Engineering Documents, (800) 854-7179, www.global.ihs.com

Send comments (with copy to BSR) to: Scott Choinski, (703) 841-3253, scott.choinski@nema.org

BSR C29.10-1989 (R201x), Wet Process Porcelain Insulators - Indoor Apparatus Type (reaffirmation of ANSI C29.10-1989 (R2002))

Covers high-voltage indoor-apparatus insulators made of wet-process porcelain and used in the transmission and distribution of electrical energy.

Single copy price: \$40.00

Obtain an electronic copy from: NEMA
<http://www.nema.org/stds/c29-10.cfm>

Order from: Global Engineering Documents, (800) 854-7179,
www.global.ihs.com

Send comments (with copy to BSR) to: Scott Choinski, (703) 841-3253,
scott.choinski@nema.org

TIA (Telecommunications Industry Association)

Revisions

BSR/TIA 855-A-201x, Telecommunications - Telephone Terminal Equipment - Stutter Dial Tone Detection Device - Performance Requirements (revision and redesignation of ANSI/TIA 855-2001)

Provides specifications for Customer Premises Equipment (CPE) devices designed to automatically detect stutter dial tone (SDT) on an analog telephone line. TIA 968-B includes regulatory requirements related to automatic stutter dialtone detection devices for connection to the network. This standard includes criteria to meet the TIA 968-B requirements and additional requirements for the performance of these devices.

Single copy price: \$82.00

Obtain an electronic copy from: <http://global.ihs.com/>

Order from: Global Engineering Documents, (800) 854-7179,
www.global.ihs.com

Send comments (with copy to BSR) to: Ronda Coulter, (703) 907-7974,
rcoulter@tiaonline.org

UL (Underwriters Laboratories, Inc.)

Revisions

BSR/UL 867-201x, Electrostatic Air Cleaners (revision of ANSI/UL 867-2007)

Covers:

- (1) Elimination of the term "Pigtail";
- (2) Revised requirements relative to arc testing of electrically charged mechanical filters;
- (3) New collector handle securement test;
- (4) New requirements for accessory installation;
- (5) New exception to clause 37.2.3 relative to chamber setup;
- (6) Clarification of the definition of steady state ozone concentration in clause 37.4.6;
- (7) Revision to peak ozone location determination test - Room dimensions;
- (8) Revision to ozone test chamber airtightness in clause 37.2.2(a)(2); and
- (9) Revisions regarding ozone test conditions and filter test iterations specified in sections 37 and 37A.

Single copy price: Contact comm2000 for pricing and delivery options

Obtain an electronic copy from: www.comm-2000.com

Order from: comm2000

Send comments (with copy to BSR) to: Kristin Andrews, (408) 754-6634,
Kristin.L.Andrews@us.ul.com

Comment Deadline: July 20, 2010

Reaffirmations and withdrawals available electronically may be accessed at: webstore.ansi.org

ASME (American Society of Mechanical Engineers)

Reaffirmations

BSR/ASME B16.22-2001 (R201x), Wrought Copper and Copper Alloy Solder Joint Pressure Fittings (reaffirmation of ANSI/ASME B16.22-2001 (R2005))

Establishes specifications for wrought copper and wrought copper alloy, solder-joint, seamless fittings, designed for use with seamless copper tube conforming to ASTM B88 (water and general plumbing systems), B280 (air conditioning and refrigeration service), and B819 (medical gas systems), as well as fittings intended to be assembled with soldering materials conforming to ASTM B32, brazing materials conforming to AWS A5.8, or with tapered pipe thread conforming to ASME B1.20.1. This Standard is allied with ASME B16.18, which covers cast copper alloy pressure fittings. This standard provides requirements for fitting ends suitable for soldering.

Single copy price: \$40.00

Order from: Mayra Santiago, ASME; ANSIBOX@asme.org

Send comments (with copy to BSR) to: Colleen O'Brien, (212) 591-7881,
obrienc@asme.org

EIA (Electronic Industries Alliance)

Revisions

BSR/EIA 364-78B-201x, Cavity-to-Cavity Leakage Bonding Integrity Test Procedure for Electrical Connectors (revision of ANSI/EIA 364-78A-2002 (R2009))

Establishes a technique for evaluating the sealing integrity of the contact cavity walls of an environmentally sealed electrical connector by detecting leakage between a given contact cavity and those adjacent to it.

Single copy price: Free

Obtain an electronic copy from: www.global.ihs.com

Order from: Global Engineering Documents, (800) 854-7179,
www.global.ihs.com

Send comments (with copy to BSR) to: Cecelia Yates, (703) 907-8026,
cyates@eca.us.org

UL (Underwriters Laboratories, Inc.)

New Standards

BSR/UL 2007A-201x, Standard for Shatter Containment of Lamps for Use in Regulated Food Establishments (new standard)

Covers shatter containment mechanisms for lamps, for use in food establishments, that are intended to prevent contamination of food. Types of lamps covered by these requirements include incandescent, halogen, linear fluorescent, pin-base compact fluorescent, screwbase compact fluorescent, high intensity discharge (HID), and solid state. These requirements do not apply to the lighting fixtures (luminaires), lamp holders or other apparatus that support the lamps and/or shatter containment mechanism.

Single copy price: Contact comm2000 for pricing and delivery options

Obtain an electronic copy from: <http://www.comm-2000.com>

Order from: comm2000

Send comments (with copy to BSR) to: Alan McGrath, (847) 664-2850,
Alan.T.McGrath@us.ul.com

Technical Reports Registered with ANSI

Technical Reports Registered with ANSI are not consensus documents. Rather, all material contained in Technical Reports Registered with ANSI is informational in nature. Technical reports may include, for example, reports of technical research, tutorials, factual data obtained from a survey carried out among standards developers and/or national bodies, or information on the "state of the art" in relation to standards of national or international bodies on a particular subject.

Immediately following the end of a 30-day announcement period in Standards Action, the Technical Report will be registered by ANSI. Please submit any comments regarding this registration to the organization indicated, with a copy to the PSA Center, American National Standards Institute, 25 West 43rd Street, New York, NY 10036 or E-Mail to psa@ansi.org.

Comment Deadline: June 20, 2010

ASME (American Society of Mechanical Engineers)

BSR/ASME TR EA-1G-2010, Guidance for ASME EA-1, Energy Assessment for Process Heating Systems (technical report)

Provides an application guide on how to utilize ASME EA-1, Energy Assessment for Process Heating Systems. This guidance document provides background and supporting information to assist in applying the standard.

Single copy price: Free

Order from: Ryan Crane, (212) 591-7004, craner@asme.org

Send comments (with copy to BSR) to: Same

Call for Comment Contact Information

The addresses listed in this section are to be used in conjunction with standards listed in Call for Comment. This section is a list of developers who have submitted standards for public review in this issue of *Standards Action* – it is not intended to be a list of all ANSI developers. Please send all address corrections to: Standards Action Editor, American National Standards Institute, 25 West 43rd Street, New York, NY 10036 or standact@ansi.org.

Order from:

ASABE

American Society of Agricultural
and Biological Engineers

2950 Niles Road
St Joseph, MI 49085
Phone: (269) 932-7015

Fax: (269) 429-3852
Web: www.asabe.org

ASME

American Society of Mechanical
Engineers

3 Park Avenue, 20th Floor
New York, NY 10016
Phone: (212) 591-7004
Fax: (212) 591-8501

Web: www.asme.org

AWWA

American Water Works
Association

6666 West Quincy Avenue
Denver, CO 80235
Phone: (303) 347-6178
Fax: (303) 795-7603

Web:
www.awwa.org/asp/default.asp

comm2000

1414 Brook Drive
Downers Grove, IL 60515

EASA

Electrical Apparatus Service
Association

1331 Baur Blvd.
St. Louis, MO 63132
Phone: (314) 993-2220

Fax: (314) 993-1269

Global Engineering Documents

Global Engineering Documents

15 Inverness Way East
Englewood, CO 80112-5704
Phone: (800) 854-7179

Fax: (303) 379-2740

IAM

The International Association of
Movers

5904 Richmond Highway
Suite 404
Alexandria, VA 22303

Phone: (703) 317-9950
Fax: (703) 317-9960
Web: www.hgfaa.org

Send comments to:

ASABE

American Society of Agricultural
and Biological Engineers

2950 Niles Road
St Joseph, MI 49085
Phone: (269) 932-7015
Fax: (269) 429-3852
Web: www.asabe.org

ASME

American Society of Mechanical
Engineers

3 Park Avenue, 20th Floor

New York, NY 10016
Phone: (212) 591-7004
Fax: (212) 591-8501
Web: www.asme.org

AWWA

American Water Works
Association

6666 West Quincy Avenue
Denver, CO 80235
Phone: (303) 347-6178
Fax: (303) 795-7603
Web:
www.awwa.org/asp/default.asp

EASA

Electrical Apparatus Service
Association

1331 Baur Blvd.
St. Louis, MO 63132
Phone: (314) 993-2220
Fax: (314) 993-1269

EIA

Electronic Industries Alliance

2500 Wilson Boulevard
Suite 310
Arlington, VA 22201
Phone: (703) 907-8026
Fax: (703) 875-8908
Web: www.eia.org

IAM

The International Association of
Movers

5904 Richmond Highway
Suite 404
Alexandria, VA 22303
Phone: (703) 317-9950
Fax: (703) 317-9960
Web: www.hhgfaa.org

NEMA (ASC C29)

National Electrical Manufacturers
Association

1300 North 17th Street, Suite 1752
Rosslyn, VA 22209
Phone: (703) 841-3253
Fax: (703) 841-3353
Web: www.nema.org

NSF

NSF International

789 N. Dixboro Road
Ann Arbor, MI 48105
Phone: (734) 827-6819
Fax: (734) 827-7875
Web: www.nsf.org

TIA

Telecommunications Industry
Association

2500 Wilson Blvd
Arlington, VA 22201
Phone: (703) 907-7974
Fax: (703) 907-7727
Web: www.tiaonline.org

UL

Underwriters Laboratories, Inc.

333 Pfingsten Road
Northbrook, IL 60062-2096
Phone: (847) 664-2850
Fax: (847) 313-2850
Web: www.ul.com/

Call for Members (ANS Consensus Bodies)

Directly and materially affected parties who are interested in participating as a member of an ANS consensus body for the standards listed below are requested to contact the sponsoring standards developer directly and in a timely manner.

CAGI (Compressed Air and Gas Institute)

Office: 1300 Sumner Avenue
Cleveland, OH 44115-2851

Contact: *Christopher Johnson*

Phone: (216) 241-7333

Fax: (216) 241-0105

E-mail: cjohnson@thomasamc.com; cagi@cagi.org

BSR/CAGI BL 300-201x, Standard for Testing, Rating, and Evaluating Blowers (new standard)

ISEA (International Safety Equipment Association)

Office: 1901 North Moore Street, Suite 808
Arlington, VA 22209

Contact: *Cristine Fargo*

Phone: (703) 525-1695

Fax: (703) 528-2148

E-mail: cfargo@safetysafetyequipment.org

BSR/ISEA 125-201x, Conformity Assessment of Safety and Personal Protective Equipment (new standard)

TIA (Telecommunications Industry Association)

Office: 2500 Wilson Blvd
Arlington, VA 22201

Contact: *Ronda Coulter*

Phone: (703) 907-7974

Fax: (703) 907-7727

E-mail: rcoulter@tiaonline.org

BSR/TIA 855-A-201x, Telecommunications - Telephone Terminal Equipment - Stutter Dial Tone Detection Device - Performance Requirements (revision and redesignation of ANSI/TIA 855-2001)

BSR/TIA 1194-201x, Resistibility to Surges of Smart Grid Equipment Connected to either DC or 120/240 V Single Phase AC, and Metallic Communication Line(s) (new standard)

UL (Underwriters Laboratories, Inc.)

Office: 333 Pflingsten Road
Northbrook, IL 60062-2096

Contact: *Alan McGrath*

Phone: (847) 664-2850

Fax: (847) 313-2850

E-mail: Alan.T.McGrath@us.ul.com

BSR/UL 2007A-201x, Standard for Shatter Containment of Lamps for Use In Regulated Food Establishments (new standard)

Final actions on American National Standards

The standards actions listed below have been approved by the ANSI Board of Standards Review (BSR) or by an ANSI-Audited Designator, as applicable.

ACMA (American Composites Manufacturers Association)

Revisions

ANSI/ICPA/ACMA UEF-1-2010, Estimating Emission Factors from Open Molding Composites Processes (revision of ANSI/ICPA/ACMA UEF-1-2009): 5/12/2010

ASME (American Society of Mechanical Engineers)

Addenda

ANSI/ASME B31E-2010, Standard for the Seismic Design and Retrofit of Above-Ground Piping Systems (addenda to ANSI/ASME B31E-2008): 5/13/2010

Revisions

ANSI/ASME B30.20-2010, Below the Hook Lifting Devices (revision of ANSI/ASME B30.20-2006): 5/13/2010

ATIS (Alliance for Telecommunications Industry Solutions)

Reaffirmations

ANSI ATIS 1000679-2004 (R2010), Interworking between Sessions Initiation Protocol (SIP) and Bearer Independent Call Control or ISDN User Part (reaffirmation of ANSI ATIS 1000679-2004): 5/13/2010

Revisions

ANSI ATIS 0600318-2010, Electrical Protection Applied to Telecommunications network Plant at Entrances to Customer Structures or Buildings (revision of ANSI ATIS 0600318-2005): 5/13/2010

ANSI ATIS 0600320-2010, Above-Baseline Electrical Protection for Designated Telecommunications Central Offices and Similar-Type Facilities Against High-Altitude Electromagnetic Pulse (HEMP) (revision of ANSI ATIS 0632000-2005): 5/13/2010

ANSI ATIS 0600332-2010, Electrical Protection of Network-Powered Broadband Facilities (revision of ANSI ATIS 0600332-2005): 5/13/2010

HPS (ASC N13) (Health Physics Society)

Reaffirmations

ANSI N13.12-1999 (R2010), Surface and Volume Radioactivity Standards for Clearance (reaffirmation of ANSI N13.12-1999): 5/13/2010

InfoComm (InfoComm International)

New Standards

ANSI/INFOCOMM 2M-2010, Audiovisual Systems Design and Coordination Components (new standard): 5/12/2010

ISA (ISA)

New National Adoptions

ANSI/ISA 95.00.01 (IEC 62264-1 Modified)-2010, Enterprise-Control System Integration - Part 1: Models and Terminology (national adoption with modifications and revision of ANSI/ISA 95.00.01-2000): 5/13/2010

ANSI/ISA 95.00.02 (IEC 62264-2 Modified)-2010, Enterprise-Control System Integration - Part 2: Object Models (national adoption with modifications and revision of ANSI/ISA 95.00.02-2001): 5/13/2010

ITI (INCITS) (InterNational Committee for Information Technology Standards)

New Standards

ANSI INCITS 456-2010, Information technology - Speaker Recognition Format for Raw Data Interchange (SIVR) (new standard): 5/13/2010

ANSI INCITS 462-2010, Information technology - Fibre Channel - Backbone - 5 (FC-BB-5) (new standard): 5/13/2010

ANSI INCITS 463-2010, Information technology - Fibre Channel - Generic Services - 6 (FC-GS-6) (new standard): 5/13/2010

Reaffirmations

ANSI INCITS 328-2000 (R2010), Helical-Scan Digital Computer Tape Cartridge, 19 mm (0.748 in) Type DD-2 (reaffirmation of ANSI INCITS 328-2000 (R2005)): 5/12/2010

ANSI INCITS 329-2000 (R2010), Magnetic Tape Cartridge, 0.50 in (12.65 mm), Serial Serpentine, 208-Track, 85 940 bpi (3383 bpmm) - DLT 5 Format (reaffirmation of ANSI INCITS 329-2000 (R2005)): 5/12/2010

ANSI INCITS 334-2000 (R2010), Magnetic Tape Cartridge for Information Interchange, 0.50 in (12.65 mm) Serial Serpentine 128-Track, 62 500 bpi (2460 bpmm) - DLT3XT Format (reaffirmation of ANSI INCITS 334-2000 (R2005)): 5/12/2010

ANSI INCITS 341-2000 (R2010), 25.4 mm (1 in) Type DCRsi Recorded Instrumentation - Digital Cartridge Tape Format (reaffirmation of ANSI INCITS 341-2000 (R2005)): 5/12/2010

INCITS/ISO/IEC 1860-1988 (R2010), Precision Reels for Magnetic Tape Used in Interchange Instrumentation Applications (reaffirmation of INCITS/ISO/IEC 1860-1988 (R2005)): 5/12/2010

INCITS/ISO/IEC 10646-2003 (R2010), Information technology - Universal Multiple-Octet Coded Character Set (UCS) (reaffirmation of INCITS/ISO/IEC 10646-2003): 5/12/2010

INCITS/ISO/IEC 11579-1:1994 (R2010), Information technology - Telecommunications and Information Exchange Between Systems - Private Integrated Services Network - Part 1: Reference Configuration for PISN Exchanges (PINX) (reaffirmation of INCITS/ISO/IEC 11579-1:1994 (R2005)): 5/12/2010

INCITS/ISO/IEC 11579-1-1994/TC1-1996 (R2010), Information technology - Telecommunications and Information Exchange Between Systems - Private Services Network - Part 1: Reference Configuration for PISN Exchanges (PINX) - Technical Corrigendum 1 (reaffirmation of INCITS/ISO/IEC 11579-1-1994/TC1-1996 (R2006)): 5/12/2010

INCITS/ISO/IEC 15521-1998 (R2010), Information Technology - 3, 81 mm Wide Magnetic Tape Cartridge - Helical Scan Recording - DDS 3 Format using 125 m length tapes (reaffirmation of INCITS/ISO/IEC 15521-1998 (R2005)): 5/12/2010

INCITS/ISO/IEC 15731-1998 (R2010), Information technology - 12, 65 mm wide magnetic tape cassette for information interchange - Helical scan recording - DTF-1 format (reaffirmation of INCITS/ISO/IEC 15731-1998 (R2005)): 5/12/2010

INCITS/ISO/IEC 15757-1998 (R2010), Information Technology - 8 mm wide magnetic tape cartridge for information interchange - Helical scan recording - DA-2 format (reaffirmation of INCITS/ISO/IEC 15757-1998 (R2005)): 5/12/2010

INCITS/ISO/IEC 15780-1998 (R2010), Information Technology - 8 mm wide magnetic tape cartridge for information interchange - Helical scan recording - AIT-1 format (reaffirmation of INCITS/ISO/IEC 15780-1998 (R2005)): 5/12/2010

Supplements

ANSI INCITS 452-2009 AMENDMENT 1-2010, Information technology - AT Attachment 8 - ATA/ATAPI Command Set (ATA8-ACS) - Amendment 1 (supplement to ANSI INCITS 452-2009): 5/13/2010

NISO (National Information Standards Organization)

Reaffirmations

ANSI/NISO Z39.18-2005 (R2010), Scientific and Technical Reports - Preparation, Presentation, and Preservation (reaffirmation of ANSI/NISO Z39.18-2005): 5/13/2010

ANSI/NISO Z39.19-2005 (R2010), Guidelines for the Construction, Format, and Management of Monolingual Controlled Vocabularies (reaffirmation of ANSI/NISO Z39.19-2005): 5/13/2010

ANSI/NISO Z39.29-2005 (R2010), Bibliographic References (reaffirmation of ANSI/NISO Z39.29-2005): 5/13/2010

ANSI/NISO Z39.84-2005 (R2010), Syntax for the Digital Object Identifier (reaffirmation of ANSI/NISO Z39.84-2005): 5/13/2010

ANSI/NISO Z39.88-2004 (R2010), OpenURL Framework for Context-Sensitive Services (reaffirmation of ANSI/NISO Z39.88-2004): 5/13/2010

UL (Underwriters Laboratories, Inc.)

Revisions

ANSI/UL 217-2010, Single and Multiple Station Smoke Alarms (revision of ANSI/UL 217-2008): 5/11/2010

ANSI/UL 217-2010a, Standard for Safety for Single and Multiple Station Smoke Alarms (revision of ANSI/UL 217-2008): 5/11/2010

ANSI/UL 943-2010, Standard for Safety for Ground-Fault Circuit-Interrupters (Bulletin dated October 3, 2008) (revision of ANSI/UL 943-2008): 5/12/2010

ANSI/UL 943-2010a, Standard for Safety for Ground-Fault Circuit-Interrupters (Bulletin dated September 11, 2009) (revision of ANSI/UL 943-2008): 5/12/2010

ANSI/UL 1086-2010, Standard for Safety for Household Trash Compactors (revision of ANSI/UL 1086-2007): 5/7/2010

ANSI/UL 1086-2010a, Standard for Safety for Household Trash Compactors (revision of ANSI/UL 1086-2007): 5/7/2010

ANSI/UL 1086-2010b, Standard for Safety for Household Trash Compactors (revision of ANSI/UL 1086-2007): 5/7/2010

VC (ASC Z80) (The Vision Council)

Revisions

ANSI Z80.9-2010, Low Vision Devices (revision of ANSI Z80.9-2004): 5/13/2010

Project Initiation Notification System (PINS)

ANSI Procedures require notification of ANSI by ANSI-accredited standards developers (ASD) of the initiation and scope of activities expected to result in new or revised American National Standards (ANS). Early notification of activity intended to reaffirm or withdraw an ANS and in some instances a PINS related to a national adoption is optional. The mechanism by which such notification is given is referred to as the PINS process. For additional information, see clause 2.4 of the ANSI Essential Requirements: Due Process Requirements for American National Standards.

Following is a list of proposed actions and new ANS that have been received recently from ASDs. Please also review the section in Standards Action entitled "American National Standards Maintained Under Continuous Maintenance" for additional or comparable information with regard to standards maintained under the continuous maintenance option. To view information about additional standards for which a PINS has been submitted and to search approved ANS, please visit www.NSSN.org, which is a database of standards information. Note that this database is not exhaustive.

Directly and materially affected interests wishing to receive more information or to submit comments are requested to contact the standards developer directly within 30 days of the publication of this announcement.

AIHA (ASC Z9) (American Industrial Hygiene Association)

Office: 2700 Prosperity Avenue Suite 250
Fairfax, VA 22031

Contact: Mili Mavely

Fax: (703) 207-8558

E-mail: mmavely@aiha.org

BSR AIHA Z9.14-201x, Methodology for Certification of a Biosafety Level 3 Lab (new standard)

Stakeholders: Federal Government; Universities; Medical and Pharmaceutical Industry; Design and Construction Professionals involved with high-containment facility design; Maintenance and Operation Professionals of high-containment facilities.

Project Need: It is estimated that there are over 1300 registered BSL-3 Laboratories in the U.S. with many more that operate at that level. Standards have not been developed for high-containment laboratory design, construction, commissioning or training standards for laboratory workers. A clear and unambiguous set of standards stating what is required to maintain the integrity of high-containment laboratories once they have been commissioned and begin operating is needed.

High-containment laboratory certification is the systematic review and evaluation of all safety features and processes associated with the laboratory (engineering controls, personal protective equipment, building and system integrity, standard operating procedures (SOPs)) and administrative controls. The methodology for certifying a BSL-3 will assist professionals in ensuring that all reasonable facility controls and prudent practices are in place to minimize, to the greatest extent possible, the risks associated with laboratory operations and the use of biohazardous materials.

ASC X9 (Accredited Standards Committee X9, Incorporated)

Office: 1212 West Street, Suite 200
Annapolis, MD 21401

Contact: Isabel Bailey

Fax: (410) 267-0961

E-mail: isabel.baileyx9@verizon.net

BSR X9.100-120-201x, Bank Deposit Tickets (revision of ANSI X9.100-120-2004)

Stakeholders: Financial services industry.

Project Need: This standard specifies certain deposit ticket parameters to aid in the processing of personal-size and business-size deposit tickets through conventional bank deposit and imaging processes.

Specifies certain deposit ticket parameters to aid in the processing of personal size and business size deposit tickets through conventional bank deposit and imaging processes. While this standard does not establish a specific design, orientation and layout for bank deposit tickets, it does provide specifications for a range within which key design elements shall be placed. Other bank-specific information is excluded from this standard.

ASME (American Society of Mechanical Engineers)

Office: 3 Park Avenue, 20th Floor (20N2)
New York, NY 10016

Contact: Mayra Santiago

Fax: (212) 591-8501

E-mail: ansibox@asme.org

BSR/ASME B89.4.10360.5-201x, Acceptance Test and Reverification Test for Coordinate Measuring Machines (CMMs) - Part 5: CMMs using single and multiple stylus contacting probing systems (new standard)

Stakeholders: Manufacturers, testing labs, research facilities.

Project Need: There is currently no standard that covers acceptance and periodic reverification tests of CMMs using single- and multiple-stylus contacting probing systems.

Specifies acceptance and periodic reverification tests of CMM performance with contacting probing systems and is only applicable to CMMs using any type of contact-probing system, and discrete point probing mode, and spherical or hemispherical stylus tip(s). This standard applies to CMMs supplied with any of the following: single-stylus probing system, multi-stylus probing systems with fixed multiple styli attached to a single probe (e.g., "star" stylus), multiple probing systems such as those with a stylus for each of their probes, systems with articulating probing, stylus and probe changing systems, manual (non-driven) CMMs. This draft is based on an existing ISO draft (ISO 10360.5). It includes a significant amount of added U. S. content, and also modifications to some of the ISO material.

ASTM (ASTM International)

Office: 100 Barr Harbor Drive
West Conshohocken, PA 19428-2959

Contact: Helene Skloff

Fax: (610) 834-7013

E-mail: hskloff@astm.org; cleonard@astm.org

BSR/ASTM WK28716-201x, New Test Method for Long-Term Evaluation of Thermoplastic Pipe Joints (new standard)

Stakeholders: Plastic piping systems industry.

Project Need: This test method provides protocols for conducting, measuring, and evaluating the long-term (1000-hr) joint performance of thermoplastic pipe that are subject to time-dependent changes in their tensile and modulus material properties.

<http://www.astm.org/DATABASE.CART/WORKITEMS/WK28716.htm>

ASTM (ASTM International)

Office: 100 Barr Harbor Drive
West Conshohocken, PA 19428-2959

Contact: Jeff Richardson

Fax: (610) 834-7067

E-mail: jrichard@astm.org

BSR/ASTM WK23106-201x, New Specification for Standard Specification for Molded Saddle Heat Fusion Fittings for Outside Diameter Controlled Polyethylene Pipe (new standard)

Stakeholders: Plastic piping systems industry.

Project Need: To develop a new standard that contains requirements for molded-saddle heat-fusion fittings intended for gas-distribution applications.

<http://www.astm.org/DATABASE.CART/WORKITEMS/WK23106.htm>

BSR/ASTM WK28743-201x, New Specification for Polyamide Gas Pressure Pipe, Tubing and Fittings (new standard)

Stakeholders: Plastic piping systems industry.

Project Need: The Polyamide Ad Hoc Group is charged with recommending whether different polyamide-type materials, which could be used in gas distribution systems, should be included in one master standard with supplemental material requirements included in annexes; or whether each material should have independent standards for material, pipe, and component requirements; or some combination of these two alternatives.

<http://www.astm.org/DATABASE.CART/WORKITEMS/WK28743.htm>

BSR/ASTM WK28746-201x, New Practice for Design, Construction, Maintenance, Use, and Safety of Ice Hockey Rinks (new standard)

Stakeholders: Sports equipment and facilities industry.

Project Need: To provide consistent safety considerations in the design, layout specifications, construction, maintenance, safe operation, and use of ice hockey playing facilities.

<http://www.astm.org/DATABASE.CART/WORKITEMS/WK28746.htm>

AWS (American Welding Society)

Office: 550 N.W. LeJeune Road
Miami, FL 33126

Contact: Rosalinda O'Neill

Fax: (305) 443-5951

E-mail: roneill@aws.org

BSR/AWS D14.7/D14.7M-201x, Recommended Practices for Surfacing and Reconditioning of Industrial Mill Rolls (revision of ANSI/AWS D14.7/D14.7M-2005)

Stakeholders: Machinery and equipment industry.

Project Need: To make updates and revisions to the 2005 edition.

Provides guidance, based upon experience, for preparing, building up, and overlaying by welding, postweld heat treating, finish machining, inspecting, and record keeping of new and reconditioned industrial mill rolls.

BSR/AWS D16.2M/D16.2-201x, Guide for Components of Robotic and Automatic Arc Welding Installations (revision of ANSI/AWS D16.2M/D16.2-2007)

Stakeholders: Robotic welding industry.

Project Need: To make updates and revisions to the 2006 edition.

Provides performance recommendations for evaluating components of a typical robotic or automatic welding installation. Emphasis is placed on the role of the welding interface. A pin arrangement and specific pin function for each location in a standardized 37-pin connector are proposed.

CAGI (Compressed Air and Gas Institute)

Office: 1300 Sumner Avenue
Cleveland, OH 44115-2851

Contact: Christopher Johnson

Fax: (216) 241-0105

E-mail: cjohnson@thomasamc.com; jboyle@thomasamc.com

BSR/CAGI BL 300-201x, Standard for Testing, Rating, and Evaluating Blowers (new standard)

Stakeholders: Blower manufacturers, end users, energy-efficiency organizations, test labs.

Project Need: There is a need to develop a simplified method of testing, rating, and evaluating the performance of blowers. Related standards that apply to positive displacement compressors and centrifugal compressors will be utilized as a resource to develop a standard specific to blowers.

Addresses methods of testing, rating, and evaluating the performance, including energy efficiency, of rotary positive-displacement blowers and centrifugal blowers and exhausters, in applications of 30 PSIG or less.

IEEE (ASC C63) (Institute of Electrical and Electronics Engineers)

Office: 445 Hoes Lane, P.O. Box 1331
Piscataway, NJ 08855-1331

Contact: Michael Kipness

Fax: (732) 562-1571

E-mail: m.kipness@ieee.org

BSR C63.10-201x, Procedures for compliance testing of unlicensed wireless devices (revision of ANSI C63.10-2009)

Stakeholders: EMC test laboratories and equipment manufacturers (software designers), EMC laboratory accreditation bodies, government agencies, manufacturers of unlicensed devices, Telecommunication Certification Bodies and TCB Council.

Project Need: Edition 1 of C63.10 was developed to consolidate the procedures for testing unlicensed wireless devices. The original PINS was limited to those procedures that were non-controversial and somewhat well defined. It was agreed that the more controversial topics would be left to Edition 2 of the standard.

Addresses the following topics to be incorporated into Edition 2:

- (a) Instrumentation requirements (dynamic range, signal conditioning) and procedures (distance correction, reporting requirements, and antenna pointing) above 1 GHz;
- (b) MIMO - to reduce testing requirements;
- (c) Band edge measurements - to distinguish between wideband and narrow band modulation and develop suitable techniques for each class;
- (d) Broadband system measurements; and
- (e) Dynamic frequency.

IEEE (Institute of Electrical and Electronics Engineers)

Office: 445 Hoes Lane
Piscataway, NJ 08854

Contact: Lisa Yacone

Fax: (732) 562-1571

E-mail: l.yacone@ieee.org

BSR/IEEE 400.4-201x, Guide for Field-Testing of Shielded Power Cable Systems Rated 5 kV and Above with Damped Alternating Current Voltage (DAC) (new standard)

Stakeholders: Electrical power utilities, industrial plants with electrical power distribution systems.

Project Need: Cables and their accessories are a significant part of any electrical distribution system and demand high reliability and long life expectancy. In order to ensure optimum performance of the power cable system, standards and guidelines have been developed that address the specific testing requirements for new and service-aged extruded and laminated dielectric insulation.

Provides the Guide for Field-Testing of Shielded Power Cable Systems Rated 5kV and Above with Damped Alternating Current Voltage (DAC).

BSR/IEEE 802.1AXbk-201x, Local and metropolitan area networks - Link Aggregation Amendment: Protocol Addressing (addenda to ANSI/IEEE 802.1AX-2009)

Stakeholders: Developers, distributors, and users of networking equipment and services, including networking integrated circuit (IC) developers and switch vendors.

Project Need: IEEE Std 802.1aj defines a Two-Port MAC Relay (TPMR), which blocks the address currently used by the 802.1AX protocols. Similarly, Provider-Bridged Networks, defined in IEEE Std 802.1Q, block the address currently used for the 802.1AX protocols. It is desirable to allow aggregated links to be selectively extended using TPMRs or Provider Bridged Networks. Changes to the protocol addressing are required to allow additional addresses to be used.

Specifies changes to the addressing used by the link aggregation control and marker protocols.

BSR/IEEE 802.3bg-201x, LAN/MAN - Specific requirements - Part 3: Carrier Sense Multiple Access with Collision Detection (CSMA/CD) Access Method and Physical Layer Specifications Amendment: Physical Layer and Management Parameters for Serial 40 Gb/s Ethernet Operation Over Single Mode Fiber (addenda to ANSI/IEEE 802.3-2009)

Stakeholders: Users and producers of systems and components for telecommunications carriers, data centers, networking systems, and multiple system operators.

Project Need: To provide multiple system operators and telecommunications operators with an IEEE 802.3 Ethernet 40-Gb/s serial PHY that provides optical compatibility with existing carrier 40-Gb/s client interfaces.

Adds a single-mode fiber Physical Medium Dependent (PMD) option for serial 40 Gb/s operation by specifying additions to, and appropriate modifications of, IEEE Std 802.3-2008 as amended by the IEEE P802.3ba project (and any other approved amendment or corrigendum).

BSR/IEEE 802.15.4-2006/Cor 1-201x, Information technology - Telecommunications and information exchange between systems - Local and metropolitan area networks - Specific requirements - Part 15.4: Wireless Medium Access Control (MAC) and Physical Layer (PHY) Specifications for Low Rate Wireless Personal Area Networks (WPANs) - Corrigendum 1 (addenda to ANSI/IEEE 802.15.4-2006)

Stakeholders: Industry consortiums such as ZigBee and HCF, as well as standards organizations such as ISA and IETF.

Project Need: To correct errors, inconsistencies, and ambiguities in IEEE Std 802.15.4 as soon as possible.

Contains substantive corrections to IEEE Std 802.15.4. This standard corrects errors, inconsistencies, and ambiguities in that standard. It does not contain new material.

BSR/IEEE 802.23-201x, Standard for Local and Metropolitan Area Networks- Emergency Services for Internet Protocol (IP) Based Citizen to Authority Communications (new standard)

Stakeholders: Emergency Service authorities and government agencies (e.g. National Emergency Number Authority (NENA), and the equivalent bodies in the rest of the world); IETF; other telecom, cellular and emergency services standards-development organizations (e.g., IETF, Third-Generation Partnership Project (3GPP), ETSI-Emergency Telecommunications (EMTEL)). Within IEEE 802, the expected stake holders will be 802.1, 802.3, 802.11, 802.16, 802.20 and 802.22 as potential Layer 2 alternatives and 802.21.

Project Need: VoIP emergency calls are currently less effective than those provided by traditional wireline and cellular networks.

Emergency calls across IEEE 802 technologies need to support regulatory requirements to assure successful completion (and all associated requirements) of these calls to the correct Public Service Access Point (PSAP), and to do so utilizing the existing set of IEEE 802 PHYs and MACs.

Defines a media-independent framework within IEEE 802 to provide consistent access and data that facilitate compliance to applicable civil authority requirements for communications systems that include IEEE 802 networks. This includes a data link layer interface for a consistent view of IEEE 802 networks by IP (Internet Protocol) based citizen-to-authority emergency services capabilities from the Internet Engineering Task Force (IETF) Emergency Context Resolution with Internet Technologies (ECRIT).

BSR/IEEE 1149.1.1-201x, Standard for Test Access Port Interface for Connection to Test Data Registers (new standard)

Stakeholders: New IEEE 1149.1-based standards such as P1687, Electronic Design Automation providers, Intellectual Property providers and their consumers, semiconductor manufacturers and other adopters of IEEE 1149.1 and its associated supply chain.

Project Need: IEEE 1149.1 is defined in such a way as to require all elements of a compliant system to be defined at once and does not provide a standard way to describe how elements of an 1149.1 system would be connected. The semiconductor industry has settled on a few dominant methods, but variations exist and some of the dominant methods are incompatible.

Defines an interface that provides for connection of test data registers to an IEEE 1149.1 Test Access Port (TAP) and its associated TAP Controller and Instruction Register.

BSR/IEEE 1819-201x, Standard for Risk-Informed Categorization and Treatment of Electrical and Electronic Equipment at Nuclear Power Generating Stations and Other Nuclear Facilities (new standard)

Stakeholders: Nuclear power plants and other nuclear facilities.

Project Need: Risk-informed methods have been established to appropriately categorize components as either safety significant or low safety significant. Application of these methods has been shown to be safety-beneficial for existing Nuclear Power Generating Stations and Nuclear Facilities. No standardized approach currently exists for the detailed application of these methods to electrical and electronic components.

Identifies and discusses criteria for risk-informed categorization and treatment of electrical and electronic components that are designated by the user to be placed into safety-significant categories at nuclear power generating stations and other nuclear facilities.

BSR/IEEE 1820-201x, Guide on the Selection of Transmission and Distribution Insulators with Respect to Cold Weather Conditions (new standard)

Stakeholders: Utilities, manufacturers, and consultants

Project Need: There is currently no available guide for helping the user in selecting an outdoor high-voltage insulator under these conditions.

Specifies procedures for selecting external insulation that is likely to be subjected to an outdoor environment that includes combinations of contamination, ice, snow, or cold fog. The selection methods are applicable to insulators, surge arresters, bushings, and other high-voltage apparatus with a rated voltage above 1 kV.

BSR/IEEE 1821-201x, Guide for Usage of Design Tools for Power Electronic Building Blocks (PEBB) and PEBB Based Systems (new standard)

Stakeholders: PEBB designers and manufacturers, end users and utilities interested in using PEBB-based systems and consultants interested in PEBB specification using model-driven approaches.

Project Need: Although many modeling tools have been developed for considering specific aspects of power electronic apparatus in power systems, there is as yet no comprehensive guide that suggests how to utilize these blocks symbiotically to speed up the design process and to optimize the functional performance of the PEBB block as a component in the larger network.

Characterizes modeling approaches and simulation tools for the design and system integration of Power Electronic Building Blocks (PEBB). This guide is applicable to power electronics in areas such as Custom Power, Flexible AC Transmission Systems (FACTS), High Voltage DC Transmission (HVDC), Distributed Generation and Energy Storage applications. These range in power levels from hundreds of kW to thousands of MW, but with emphasis on the 1 MW to hundreds of MW.

BSR/IEEE 1901.2-201x, Standard for Low Frequency (less than 500 kHz) Narrow Band Power Line Communications for Smart Grid Applications (new standard)

Stakeholders: Automotive Pluggable Electric Vehicle (PEV), Pluggable Hybrid Electric Vehicle (PHEV) companies, metering companies, Electric Vehicle Service Equipment (EVSE) manufacturers, global utilities, consumers, appliance manufacturers, lighting companies, and other various domains

Project Need: Global Smart Grid projects investigating deployments using LF NB power line communications are moving ahead quickly with limited unified, global standard guidance.

Specifies communications for low-frequency (less than 500 kHz) narrowband power-line devices via alternating-current and direct-current electric power lines. This standard supports indoor and outdoor communications over low-voltage line (line between transformer and meter, less than 1000 V), through transformer low-voltage to medium-voltage (1000 V up to 72 kV) and through transformer medium-voltage to low-voltage power lines in both urban and in long-distance (multikilometer) rural communications. The standard uses transmission frequencies of less than 500 kHz.

BSR/IEEE 11073-10413-201x, Standard for Health informatics - Personal health device communication - Device specialization - Respiration rate monitor (new standard)

Stakeholders: People who use personal health devices in home and mobile environments, personal health device vendors, personal health manager vendors, institutions that may ultimately receive data from these devices (e.g., hospitals, doctor offices, diet and fitness companies), payors (e.g., insurance companies), regulatory agencies, telemedicine consultants and businesses.

Project Need: The applications for personal telehealth devices differ sufficiently from other ISO/IEEE 11073 point-of-care medical devices so as to require derivative standards tailored to address the particular needs of the personal telehealth market. Implementers of this standard will have a clear definition of what is required to implement the interoperable communication functionality for devices that monitor respiration rate.

Within the context of the ISO/IEEE 11073 family of standards for device communication, this standard establishes a normative definition of the communication between devices (agents) that monitor respiration rate and managers (e.g., cell phones, personal computers, personal health appliances, set top boxes) in a manner that enables plug-and-play interoperability. It leverages appropriate portions of existing standards including ISO/IEEE 11073 terminology and IEEE Std 11073-20601 information models. It specifies the use of specific term codes, formats, and behaviors in telehealth environments restricting optionality in base frameworks in favor of interoperability.

BSR/IEEE 60079-30-1-201x, Standard for Explosive Atmospheres - Part 30-1: Electrical Resistance Trace Heating - General and Testing Requirements for Industrial Applications (new standard)

Stakeholders: Manufacturers of resistance heating cable, designers of heat-tracing systems, users of heat-tracing systems, e.g., petroleum, chemical, power and energy industries, and certification agencies.

Project Need: The representation and members of the IEEE Working Group and the IEC Maintenance Team are very similar and the documents have migrated over the years to very similar requirements. Therefore, in the spirit of harmonization and less cost to industry, the joint development is needed.

Specifies general and testing requirements for electrical resistance trace heaters for application in explosive gas atmospheres. The standard covers trace heaters that may comprise either factory- or field- (work-site) assembled units, and which may be series heating cables, parallel heating cables or heating pads and heating panels that have been assembled and/or terminated in accordance with the manufacturer's instructions.

BSR/IEEE 60079-30-2-201x, Standard for Explosive Atmospheres - Part 30-2: Electrical Resistance Trace Heating - Application Guide for Design, Installation and Maintenance for Industrial Applications (new standard)

Stakeholders: Manufacturers of resistance heating cable, designers of heat-tracing systems, users of heat-tracing systems, e.g., petroleum, chemical, power and energy industries, and certification agencies.

Project Need: The representation and members of the IEEE Working Group and the IEC Maintenance Team are very similar and the documents have migrated over the years to very similar requirements. Therefore, in the spirit of harmonization and less cost to industry, the joint development is needed.

Provides guidance for the application of electrical-resistance trace heating systems in areas where explosive gas atmospheres may be present, with the exception of those classified as zone 0. This standard provides recommendations for the design, installation, maintenance and repair of trace heating equipment and associated control and monitoring equipment. It does not cover devices that operate by induction heating, skin-effect heating, or direct pipeline heating, nor those intended for stress relieving.

BSR/IEEE C37.241-201x, Guide for Application of Optical Instrument Transformers for Protective Relaying (new standard)

Stakeholders: Electric Power Industry.

Project Need: Optical sensor systems are a proven technology for both current and voltage measurement applications. However, there are no available standards or guides on the application or selection of this technology for protective relaying. This guide will address some of the key issues that have to be considered when using an optical instrument transformer for protective relaying applications.

Provides guidance on the use of optical voltage and current sensor systems for protective relaying - including selection, installation, testing, and operations.

BSR/IEEE C57.155-201x, Guide for Interpretation of Gases Generated in Natural Ester and Synthetic Ester Immersed Transformers (new standard)

Stakeholders: Transformer operators, Dielectric laboratory technicians, and repair facilities.

Project Need: Laboratories in North America have reported a large increase in the samples submitted for analysis during the past year. Based on this report, a summary of the available information is needed to instruct transformer operators on the evaluating the sample results for fluids in natural-ester- and synthetic-ester-filled transformers. There is a very limited amount of field data so the Guide will include recent laboratory experience results.

Covers Natural- and Synthetic-Ester-immersed transformers. This guide addresses the following:

- The theory of combustible gas generation in a natural and synthetic ester filled transformer;
- Interpretation of the dissolved gas analysis results;
- Recommended actions based on the interpretation of dissolved gas analysis results; and
- A bibliography of related literature.

BSR/IEEE C62.44-201x, Guide for the Application of Low-Voltage (1000 Volts rms or Less) Surge Protective Devices Used on Secondary Distribution Systems (Between the Transformer Low-Voltage Terminals and the Line Side of the Service Entrance Panel) (new standard)

Stakeholders: Worldwide surge protection device community, such as test engineers, manufacturers, writers of other standards, consultants, and specifiers.

Project Need: Currently, there is no application guide for secondary arresters. This project will provide the necessary guidance for the fast-moving technology that presently exists for secondary arresters.

Encompasses the application of surge-protective devices (secondary arresters) from the secondary terminals of the distribution transformer to the line side of the service entrance panel. This guide provides insight into the use of C62.34 Standard for Test Methods and Performance of Low-Voltage (1000 V or Less) Surge Protective Devices Used on Secondary Distribution Systems (Between the Transformer Low-Voltage Terminals and the Line Side of the Service Entrance Equipment). Also, this guide addresses coordination from the primary arrester to sensitive loads and grounding practices.

ISEA (International Safety Equipment Association)

Office: 1901 North Moore Street, Suite 808
Arlington, VA 22209

Contact: *Cristine Fargo*

Fax: (703) 528-2148

E-mail: cfargo@safetysafetyequipment.org

BSR/ISEA 125-201x, Conformity Assessment of Safety and Personal Protective Equipment (new standard)

Stakeholders: Manufacturers, test labs, certification organizations, product purchasers and specifiers.

Project Need: Fills a void in the safety equipment industry.

Establishes criteria for conformity assessment of safety and personal protective equipment that is sold with claims of compliance with accepted industry product-performance standards. Specific provisions are described for:

- qualification performance testing data collection and maintenance;
- periodic verification;
- substantiation of processes to maintain manufacturing quality;
- obligations and consequences in the case of non-compliance; and
- roles and responsibilities of manufacturers, testing organizations, and certification organizations that participate in the process.

MedBiq (MedBiquitous Consortium)

Office: 401 E. Pratt Street, Suite 1700
Baltimore, MD 21202

Contact: *Valerie Smothers*

Fax: (410) 385-6055

E-mail: valerie.smothers@medbiq.org

BSR/MEDBIQ CF.10.1-201x, Competency Framework (new standard)

Stakeholders: Medical schools, hospitals, certifying boards, licensing boards, government agencies, professional associations, continuing education providers, information technology vendors, accreditation organizations, healthcare professionals.

Project Need: The use of outcome and competency frameworks is a growing part of healthcare education and maintenance of certification. Currently, there is no standard way to represent these frameworks, and therefore no easy way to import/export competency frameworks across systems.

Competency Framework leverages the Healthcare Learning Object Metadata and may reference external competency definitions of different formats. It contains metadata about the framework as well as relationships (hierarchical and non-hierarchical) among competency objects and potentially existing frameworks that comprise the Competency Framework.

NACE (NACE International, the Corrosion Society)

Office: 1440 South Creek Drive
Houston, TX 77084-4906

Contact: *Daniela Matthews*

Fax: (281) 228-6387

E-mail: daniela.matthews@nace.org

BSR/NACE SP0508-201x, Methods of Validating Equivalence to ISO 8502-9 on Measurement of the Levels of Soluble Salts (revision of ANSI/NACE SP0508-2008)

Stakeholders: Engineers, specification writers, test equipment suppliers, contractors.

Project Need: To provide a way to establish equivalence by testing and comparing results of the tests to meet established criteria that would be achieved using the method specified in ISO 8502-9.

The assessment and determination of surface contamination (by salts) prior to application of protective coatings is critical to their service life expectancy. Determination of the level of surface cleanliness is conducted by extraction of soluble salt contaminants following ISO 8502-6 -The Bresle method, part of ISO 8502-9. The determination of the level of salt is performed by following ISO 8502-9 - Field method for the conductometric determination of water-soluble salts. The objective of this standard is to determine whether methods other than the Bresle patch application method are suitable alternatives for measuring salt contamination in the field.

TIA (Telecommunications Industry Association)

Office: 2500 Wilson Blvd
Arlington, VA 22201

Contact: Ronda Coulter

Fax: (703) 907-7727

E-mail: rcoulter@tiaonline.org

BSR/TIA 1194-201x, Resistibility to Surges of Smart Grid Equipment
Connected to either DC or 120/240 V Single Phase AC, and Metallic
Communication Line(s) (new standard)

Stakeholders: Telecommunications Industry Association.

Project Need: This project applies to equipment which is connected to metallic conductive communication line(s) and either a DC power source, or a 120/240 V single-phase AC power service with the neutral grounded at the service entrance. Most standards for the resistibility of equipment to electrical surges assume that a zero (or very low) impedance exists among all the grounds in the equipment, or among the connections to separate earth grounds.

Applies to equipment that is connected to metallic conductive communication line(s) and either a DC power source, or a 120/240 V single phase AC power service with the neutral grounded at the service entrance. Most standards for the resistibility of equipment to electrical surges assume that a zero (or very low) impedance exists among all the grounds in the equipment, or among the connections to separate earth grounds.

American National Standards Maintained Under Continuous Maintenance

The ANSI Essential Requirements: Due Process Requirements for American National Standards provide two options for the maintenance of American National Standards (ANS): periodic maintenance (see clause 4.7.1) and continuous maintenance (see clause 4.7.2). Continuous maintenance is defined as follows:

The standard shall be maintained by an accredited standards developer. A documented program for periodic publication of revisions shall be established by the standards developer. Processing of these revisions shall be in accordance with these procedures. The published standard shall include a clear statement of the intent to consider requests for change and information on the submittal of such requests. Procedures shall be established for timely, documented consensus action on each request for change and no portion of the standard shall be excluded from the revision process. In the event that no revisions are issued for a period of four years, action to reaffirm or withdraw the standard shall be taken in accordance with the procedures contained in the ANSI Essential Requirements.

The Executive Standards Council (ExSC) has determined that for standards maintained under the Continuous Maintenance option, separate PINS announcements are not required. The following ANSI Accredited Standards Developers have formally registered standards under the Continuous Maintenance option.

- AAMI (Association for the Advancement of Medical Instrumentation)
- AAMVA (American Association of Motor Vehicle Administrators)
- AGA (American Gas Association)
- AGRSS, Inc. (Automotive Glass Replacement Safety Standards Committee, Inc.)
- ASC X9 (Accredited Standards Committee X9, Incorporated)
- ASHRAE (American Society of Heating, Refrigerating and Air-Conditioning Engineers, Inc.)
- ASME (American Society of Mechanical Engineers)
- ASTM (ASTM International)
- GEIA (Greenguard Environmental Institute)
- HL7 (Health Level Seven)
- MHI (ASC MH10) (Material Handling Industry)
- NBBPVI (National Board of Boiler and Pressure Vessel Inspectors)
- NCPDP (National Council for Prescription Drug Programs)
- NISO (National Information Standards Organization)
- NSF (NSF International)
- TIA (Telecommunications Industry Association)
- UL (Underwriters Laboratories, Inc.)

To obtain additional information with regard to these standards, such as contact information at the ANSI accredited standards developer, please visit ANSI Online at www.ansi.org, select Internet Resources, click on "Standards Information," and see "American National Standards Maintained Under Continuous Maintenance". This information is also available directly at www.ansi.org/publicreview.

Alternatively, you may contact the Procedures & Standards Administration Department (PSA) at psa@ansi.org or via fax at 212-840-2298. If you request that information be provided via E-mail, please include your E-mail address; if you request that information be provided via fax, please include your fax number. Thank you.



ISO Draft International Standards

This section lists proposed standards that the International Organization for Standardization (ISO) is considering for approval. The proposals have received substantial support within the technical committees or subcommittees that developed them and are now being circulated to ISO members for comment and vote. Standards Action readers interested in reviewing and commenting on these documents should order copies from ANSI.

Comments

Comments regarding ISO documents should be sent to Rachel Howenstine, at ANSI's New York offices (isot@ansi.org). The final date for offering comments is listed after each draft.

Ordering Instructions

ISO Drafts can be made available by contacting ANSI's Customer Service department. Please e-mail your request for an ISO Draft to Customer Service at sales@ansi.org. When making your request, please provide the date of the Standards Action issue in which the draft document you are requesting appears.

AGRICULTURAL FOOD PRODUCTS (TC 34)

ISO/DIS 7700-2, Food products - Checking the performance of moisture meters in use - Part 2: Moisture meters for oilseeds - 8/18/2010, \$40.00

AIRCRAFT AND SPACE VEHICLES (TC 20)

ISO/DIS 10785, Space systems - Bellows - Design and operation - 8/11/2010, \$71.00

ISO/DIS 10794, Space systems - Programme management - Material, mechanical parts and processes - 8/15/2010, \$125.00

APPLICATIONS OF STATISTICAL METHODS (TC 69)

ISO/DIS 22514-6, Statistical methods in process management - Capability and performance - Part 6: Process capability statistics for characteristics following a multivariate normal distribution - 8/15/2010, \$82.00

FISHERIES AND AQUACULTURE (TC 234)

ISO/DIS 12875, Traceability of finfish products - Specification on the information to be recorded in captured finfish distribution chains - 8/19/2010, \$88.00

FLOOR COVERINGS (TC 219)

ISO/DIS 11638, Resilient floor coverings - Heterogeneous poly(vinyl chloride) flooring on foam - Specification - 8/15/2010, \$33.00

ISO/DIS 24343-2, Resilient and laminate floor coverings - Determination of indentation and residual indentation - Part 2: Resilient floor covering: Short-term residual indentation - 8/11/2010, \$40.00

FLUID POWER SYSTEMS (TC 131)

ISO/DIS 6953-3, Pneumatic fluid power - Compressed air pressure regulators and filter-regulators - Part 3: Alternative test methods for measuring the flow-rate characteristics of pressure regulators - 8/18/2010, \$102.00

INFORMATION AND DOCUMENTATION (TC 46)

ISO/DIS 27730, Information and documentation - International standard collection identifier (ISC1) - 8/12/2010, \$53.00

LEATHER (TC 120)

ISO/DIS 16131, Leather - Upholstery leather characteristics - Selection of leather for furniture - 8/15/2010, \$53.00

MECHANICAL TESTING OF METALS (TC 164)

ISO/DIS 12108, Metallic materials - Fatigue testing - Fatigue crack growth method - 8/12/2010, \$107.00

OPTICS AND OPTICAL INSTRUMENTS (TC 172)

ISO/DIS 23584-2, Optics and photonics - Specification of reference dictionary - Part 2: Classes and properties definitions - 8/18/2010, \$185.00

PLASTICS PIPES, FITTINGS AND VALVES FOR THE TRANSPORT OF FLUIDS (TC 138)

ISO/DIS 19893, Plastics piping systems - Thermoplastics pipes and fittings for hot and cold water - Test method for the resistance of mounted assemblies to temperature cycling - 8/12/2010, \$46.00

ISO 8483/DAmD1, Glass-reinforced thermosetting plastics (GRP) pipes and fittings - Test methods to prove the design of bolted flange joints - Draft amendment 1 - 8/19/2010, \$29.00

ISO 8533/DAmD1, Glass-reinforced thermosetting plastics (GRP) pipes and fittings - Test methods to prove the design of cemented or wrapped joints - Draft Amendment 1 - 8/19/2010, \$29.00

ISO 15306/DAmD1, Glass-reinforced thermosetting plastics (GRP) pipes - Determination of the resistance to cyclic internal pressure - Draft Amendment 1 - 8/19/2010, \$29.00

WATER QUALITY (TC 147)

ISO/DIS 29201, Water quality - The variability of test results and the uncertainty of measurement of microbiological enumeration methods - 8/12/2010, \$125.00

Newly Published ISO and IEC Standards



Listed here are new and revised standards recently approved and promulgated by ISO - the International Organization for Standardization – and IEC – the International Electrotechnical Commission. Most are available at the ANSI Electronic Standards Store (ESS) at www.ansi.org. All paper copies are available from Standards resellers (<http://webstore.ansi.org/faq.aspx#resellers>).

ISO Standards

AIRCRAFT AND SPACE VEHICLES (TC 20)

ISO 11639:2010, Aerospace - Part numbering for hose assemblies, \$57.00

CRANES (TC 96)

ISO 7752-1:2010, Cranes - Control layout and characteristics - Part 1: General principles, \$57.00

ISO 7752-3:2010, Cranes - Control layout and characteristics - Part 3: Tower cranes, \$43.00

ELEVATING WORK PLATFORMS (TC 214)

ISO 16368:2010, Mobile elevating work platforms - Design, calculations, safety requirements and test methods, \$193.00

EQUIPMENT FOR FIRE PROTECTION AND FIRE FIGHTING (TC 21)

ISO 7240-20:2010, Fire detection and alarm systems - Part 20: Aspirating smoke detectors, \$157.00

ISO 7240-25:2010, Fire detection and fire alarm systems - Part 25: Components using radio transmission paths, \$141.00

ISO 21927-2/Amd1:2010, Smoke and heat control systems - Part 2: Specification for natural smoke and heat exhaust ventilators - Amendment 1, \$16.00

ISO 21927-3/Amd1:2010, Smoke and heat control systems - Part 3: Specification for powered smoke and heat exhaust ventilators - Amendment 1, \$16.00

FLUID POWER SYSTEMS (TC 131)

ISO 5597:2010, Hydraulic fluid power - Cylinders - Dimensions and tolerances of housings for single-acting piston and rod seals in reciprocating applications, \$86.00

ISO 27407:2010, Hydraulic fluid power - Marking of performance characteristics on hydraulic filters, \$73.00

HYDROGEN ENERGY TECHNOLOGIES (TC 197)

ISO 26142:2010, Hydrogen detection apparatus - Stationary applications, \$116.00

LIFTS, ESCALATORS, PASSENGER CONVEYORS (TC 178)

ISO 4190-1:2010, Lift (Elevator) installation - Part 1: Class I, II, III and VI lifts, \$116.00

MATERIALS FOR THE PRODUCTION OF PRIMARY ALUMINIUM (TC 226)

ISO 12315:2010, Aluminium oxide primarily used for production of aluminium - Method for calculating the Al₂O₃ content of smelter-grade alumina, \$43.00

PETROLEUM PRODUCTS AND LUBRICANTS (TC 28)

ISO 10307-2/Cor1:2010, Petroleum products - Total sediment in residual fuel oils - Part 2: Determination using standard procedures for ageing - Corrigendum, FREE

ROAD VEHICLES (TC 22)

ISO 4513:2010, Road vehicles - Visibility - Method for establishment of eyellipses for drivers eye location, \$129.00

RUBBER AND RUBBER PRODUCTS (TC 45)

ISO 28641:2010, Rubber compounding ingredients - Organic chemicals - General test methods, \$149.00

TIMBER STRUCTURES (TC 165)

ISO 22389-1:2010, Timber structures - Bending strength of I-beams - Part 1: Testing, evaluation and characterization, \$104.00

TRACTORS AND MACHINERY FOR AGRICULTURE AND FORESTRY (TC 23)

ISO 11784/Amd2:2010, Agricultural equipment - Animal electronic identification - Code structure - Amendment 2: Indication of an advanced transponder, \$16.00

ISO/IEC JTC 1, Information Technology

ISO/IEC 14496-26:2010, Information technology - Coding of audio-visual objects - Part 26: Audio conformance, \$277.00

ISO/IEC 15421:2010, Information technology - Automatic identification and data capture techniques - Bar code master test specifications, \$65.00

ISO/IEC 18051:2010, Information technology - Telecommunications and information exchange between systems - Services for Computer Supported Telecommunications Applications (CSTA) Phase III, \$320.00

ISO/IEC 18056:2010, Information technology - Telecommunications and information exchange between systems - XML protocol for Computer Supported Telecommunications Applications (CSTA) Phase III, \$292.00

ISO/IEC 29500-3/Cor1:2010, Information technology - Document description and processing languages - Office Open XML File Formats - Part 3: Markup Compatibility and Extensibility - Corrigendum, FREE

IEC Standards

AUDIO, VIDEO AND MULTIMEDIA SYSTEMS AND EQUIPMENT (TC 100)

IEC 61834-4 Amd.1 Ed. 1.0 b:2010, Amendment 1 - Recording - Helical-scan digital video cassette recording system using 6,35 mm magnetic tape for consumer use (525-60, 625-50, 1125-60 and 1125-50 systems) - Part 4: Pack header table and contents, \$107.00

CABLES, WIRES, WAVEGUIDES, R.F. CONNECTORS, AND ACCESSORIES FOR COMMUNICATION AND SIGNALLING (TC 46)

IEC/TR 62153-4-1 Ed. 2.0 en:2010, Metallic communication cable test methods - Part 4-1: Electromagnetic compatibility (EMC) - Introduction to electromagnetic (EMC) screening measurements, \$235.00

ELECTRICAL INSTALLATIONS OF BUILDINGS (TC 64)

IEC 60364-7-702 Ed. 3.0 b:2010, Low-voltage electrical installations - Part 7-702: Requirements for special installations or locations - Swimming pools and fountains, \$107.00

FIBRE OPTICS (TC 86)

IEC 60793-1-31 Ed. 2.0 en:2010, Optical fibres - Part 1-31: Measurement methods and test procedures - Tensile strength, \$107.00

IEC 60793-1-32 Ed. 2.0 en:2010, Optical fibres - Part 1-32: Measurement methods and test procedures - Coating strippability, \$51.00

FUSES (TC 32)

IEC 60269-3 Ed. 4.0 b:2010, Low-voltage fuses - Part 3: Supplementary requirements for fuses for use by unskilled persons (fuses mainly for household or similar applications) - Examples of standardized systems of fuses A to F, \$275.00

INDUSTRIAL-PROCESS MEASUREMENT AND CONTROL (TC 65)

IEC 61508-1 Ed. 2.0 b:2010, Functional safety of electrical/electronic/programmable electronic safety-related systems - Part 1: General requirements, \$235.00

IEC 61508-2 Ed. 2.0 b:2010, Functional safety of electrical/electronic/programmable electronic safety-related systems - Part 2: Requirements for electrical/electronic/programmable electronic safety-related systems, \$260.00

IEC 61508-3 Ed. 2.0 b:2010, Functional safety of electrical/electronic/programmable electronic safety-related systems - Part 3: Software requirements, \$265.00

IEC 61508-4 Ed. 2.0 b:2010, Functional safety of electrical/electronic/programmable electronic safety-related systems - Part 4: Definitions and abbreviations, \$143.00

IEC 61508-5 Ed. 2.0 b:2010, Functional safety of electrical/electronic/programmable electronic safety-related systems - Part 5: Examples of methods for the determination of safety integrity levels, \$179.00

IEC 61508-6 Ed. 2.0 b:2010, Functional safety of electrical/electronic/programmable electronic safety-related systems - Part 6: Guidelines on the application of IEC 61508-2 and IEC 61508-3, \$265.00

IEC 61508-7 Ed. 2.0 b:2010, Functional safety of electrical/electronic/programmable electronic safety-related systems - Part 7: Overview of techniques and measures, \$275.00

NUCLEAR INSTRUMENTATION (TC 45)

IEC 62465 Ed. 1.0 b:2010, Nuclear power plants - Instrumentation and control important to safety - Management of ageing of electrical cabling systems, \$143.00

IEC 62484 Ed. 1.0 b:2010, Radiation protection instrumentation - Spectroscopy-based portal monitors used for the detection and identification of illicit trafficking of radioactive material, \$158.00

PERFORMANCE OF HOUSEHOLD ELECTRICAL APPLIANCES (TC 59)

IEC/TR 62617 Ed. 1.0 en:2010, Home laundry appliances - Uncertainty reporting of measurements, \$61.00

QUANTITIES AND UNITS, AND THEIR LETTER SYMBOLS (TC 25)

IEC 60027-7 Ed. 1.0 b:2010, Letter symbols to be used in electrical technology - Part 7: Power generation, transmission and distribution, \$128.00

SAFETY OF HOUSEHOLD AND SIMILAR ELECTRICAL APPLIANCES (TC 61)

IEC 60335-1 Ed. 5.0 b:2010, Household and similar electrical appliances - Safety - Part 1: General requirements, \$281.00

IEC 60335-2-109 Ed. 1.0 b:2010, Household and similar electrical appliances - Safety - Part 2-109: Particular requirements for UV radiation water treatment appliances, \$87.00

SEMICONDUCTOR DEVICES (TC 47)

IEC/TR 61967-1-1 Ed. 1.0 b:2010, Integrated circuits - Measurement of electromagnetic emissions - Part 1-1: General conditions and definitions - Near-field scan data exchange format, \$204.00

SWITCHGEAR AND CONTROLGEAR (TC 17)

IEC 62271-101 Amd.1 Ed. 1.0 b:2010, Amendment 1 - High-voltage switchgear and controlgear - Part 101: Synthetic testing, \$77.00

Proposed Foreign Government Regulations

Call for Comment

U.S. manufacturers, exporters, regulatory agencies and standards developing organizations may be interested in proposed foreign technical regulations issued by Member countries of the World Trade Organization (WTO). In accordance with the WTO Agreement on Technical Barriers to Trade (TBT Agreement), Members are required to report proposed technical regulations that may significantly affect trade to the WTO Secretariat in Geneva, Switzerland. In turn, the Secretariat disseminates the information to all WTO Members. The purpose of this requirement is to provide global trading partners with an opportunity to review and comment on the regulations before they become final.

The National Center for Standards and Certification Information (NCSCI) at the National Institute of Standards and Technology

(NIST), distributes these proposed foreign technical regulations to U.S. stakeholders via an online service, Notify U.S. Notify U.S. is an e-mail and Web service that allows interested U.S. parties to register, obtain notifications, and read full texts of regulations from countries and for industry sectors of interest to them. To register for Notify U.S., please go to Internet URL: <http://www.nist.gov/notifyus/> and click on "Subscribe".

NCSCI is the WTO TBT Inquiry Point for the U.S. and receives all notifications and full texts of regulations to disseminate to U.S. Industry. For further information, please contact: NCSCI, NIST, 100 Bureau Drive, Gaithersburg, MD 20899-2160; Telephone: (301) 975-4040; Fax: (301) 926-1559; E-mail: ncsci@nist.gov or notifyus@nist.gov.

Information Concerning

American National Standards

INCITS Executive Board

ANSI Accredited SDO and US TAG to ISO/IEC JTC 1, Information Technology

The InterNational Committee for Information Technology Standards (INCITS), an ANSI accredited SDO, is the forum for information technology developers, producers and users to create and maintain formal de jure IT standards. INCITS' mission is to promote the effective use of Information and Communication Technology through standardization in a way that balances the interests of all stakeholders and increases the global competitiveness of the member organizations.

The INCITS Executive Board serves as the consensus body with its oversight of programs of its 30+ Technical Committees. Additionally, the INCITS Executive Board exercises international leadership in its role as the US Technical Advisory Group (TAG) to ISO/IEC JTC 1, Information Technology.

The INCITS Executive Board seeks to broaden its membership base and is recruiting new participants in all membership categories:

- special interest (user, academic, consortia)
- non-business (government and major/minor SDOs)
- business (large/small businesses and consultants)

Membership in the INCITS Executive Board is open to all directly and materially affected parties in accordance with INCITS membership rules. To find out more about participating on the INCITS Executive Board, please contact Jennifer Garner at 202-626-5737 or jgarner@itic.org.

ANSI Accredited Standards Developers

Administrative Reaccreditation

Business and Institutional Furniture Manufacturers Association (BIFMA International)

The Business and Institutional Furniture Manufacturers Association (BIFMA International), a full ANSI organizational member, has been administratively reaccredited at the direction of ANSI's Executive Standards Council, under operating procedures revised to bring the document into compliance with the 2010 version of the ANSI Essential Requirements, effective May 18, 2010. For additional information, please contact: Mr. David Panning, Director of Technical Services, BIFMA International, 678 Front Street, Suite 150, Grand Rapids, MI 49504-5368; PHONE: (616) 285-3963; FAX: (616) 285-3765; E-mail: dpanning@bifma.org.

Maintenance of Accreditation

ASIS International

At the direction of ANSI's Executive Standards Council, the accreditation of the ASIS International, a full ANSI Organizational Member, has been administratively maintained using operating procedures containing limited revisions under its last date of reaccreditation (March 19, 2010), effective May 19, 2010. For additional information, please contact: Ms. Sue Carioti, Director, Standards & Guidelines, ASIS International, 1625 Prince Street, Alexandria, VA 22314-2818; PHONE: (703) 518-1416; E-mail: Sue.Carioti@asisonline.org.

ANSI Accreditation Program for Third Party Product Certification Agencies

Request for Scope Extension

Compliance Certification Services (UL CCS)

Comment Deadline: June 21, 2010

Compliance Certification Services (UL CCS), an ANSI-accredited certification body, has requested a scope extension of ANSI accreditation to include the following scope(s):

A. Japan MIC Telecommunications Business Law

- A1. Terminal equipment for purpose of calling
- A2. Other Terminal equipment

B. Japan MIC Radio Law

- B1. Specified Radio Equipment specified in Article 38-2, paragraph 1, item 1 of the Radio Law (MIC)
- B2. Specified Radio Equipment specified in Article 38-2, paragraph 1, item 2 of the Radio Law
- B3. Specified Radio Equipment specified in Article 38-2, paragraph 1, item 3 of the Radio Law

Please send your comments by June 21, 2010 to Reinaldo Balbino Figueiredo, Sr. Program Director, Product Certifier Accreditation, American National Standards Institute, 1819 L Street, NW, 6th Floor, Washington, DC 20036, FAX: (202) 293-9287 or E-mail: rfigureir@ansi.org, or Nikki Jackson, Program Manager, Product Certifier Accreditation, American National Standards Institute, 1819 L Street, NW, 6th Floor, Washington, DC 20036 FAX: (202) 293-9287 or E-mail: njackson@ansi.org.

ANSI Accreditation Program for Greenhouse Gas Verification/Validation Bodies

Applications for Accreditation

Jacobs Engineering Group, Inc.

Comment Deadline: June 21, 2010

In accordance with the following ISO standards:

ISO 14065:2007, Greenhouse gases - Requirements for greenhouse gas validation and verification bodies for use in accreditation or other forms of recognition

ISO 14064-3:2006, Greenhouse gases - Part 3: Specification with guidance for the validation and verification of greenhouse gas assertions

Jacobs Engineering Group, Inc.

5995 Rogerdale Road
Houston, TX 77072

has submitted a formal application for accreditation to ANSI for the following:

Activities:

Verification of assertions related to GHG emissions and removals at the organization level

Scopes:

1. General
2. Manufacturing
3. Power Generation
4. Electric Power Transactions
5. Mining and Mineral Production
7. Chemical Production
8. Oil and Gas Extraction, Production and Refining, included Petrochemicals
9. Waste

Please send your comments by June 21, 2010 to Ann Bowles, Program Manager GHG Program, American National Standards Institute, 1819 L Street, NW, 6th Floor, Washington, DC 20036, FAX: (202) 293-9287, or E-mail: abowles@ansi.org.

TRA Certification, Inc.

Comment Deadline: June 21, 2010

In accordance with the following ISO standards:

ISO 14065:2007, Greenhouse gases - Requirements for greenhouse gas validation and verification bodies for use in accreditation or other forms of recognition

ISO 14064-3:2006, Greenhouse gases - Part 3: Specification with guidance for the validation and verification of greenhouse gas assertions

TRA Certification, Inc.

700 East Beardsley Ave.
Elkhart, IN 46515

has submitted formal application for accreditation by ANSI for the following scopes and activities:

Verification of assertions related to GHG emissions and removals at the project level

- Livestock
- Waste Handling and Disposal

Validation of assertions related to GHG emission reductions & removals at the project level

- Livestock
- Waste Handling and Disposal

Verification of assertions related to GHG emissions and removals at the organization level:

- Waste
- Agriculture, Forestry and Other Land Use

Please send your comments by June 21, 2010 to Ann Bowles, Program Manager GHG Program, American National Standards Institute, 1819 L Street, NW, 6th Floor, Washington, DC 20036, FAX: (202) 293-9287 or e-mail: abowles@ansi.org

Initial Accreditation

SAI Global Certification Services PTY, Ltd.

Comment Deadline: June 21, 2010

SAI Global Certification Services Pty, Ltd

John Fraser
20 Carlson Court, Suite 100
Toronto, Ontario M9W 7K6, Canada
PHONE: (416) 401-8671
E-mail: john.fraser@qmi-saiglobal.com

On May 13, 2010, the ANSI Greenhouse Gas Validation/Verification Accreditation Committee voted to approve initial accreditation for SAI Global Certification Services Pty, Ltd for the following:

Standards:

ISO 14065, Greenhouse gases – Requirements for greenhouse gas validation and verification bodies for use in accreditation or other forms of recognition

ISO 14064-3, Greenhouse gases - Specification with guidance for the validation and verification of greenhouse gas assertions

Activities:

Verification of assertions related to GHG emissions and removals at the organization-level

Scopes:

- Group 1 – General
- Group 2 – Manufacturing
- Group 3 – Power Generation

Please send your comments by June 21, 2010 to Ann Bowles, Program Manager GHG Program, American National Standards Institute, 1819 L Street, NW, 6th Floor, Washington, DC 20036, FAX: (202) 293-9287 or E-mail: abowles@ansi.org.

ANSI-ASQ National Accreditation Board (ANAB)

ISO 14001 Environmental Management Systems

Notice of Accreditation

Certification Body

Bureau of Standards Jamaica d.b.a. National Certification Body of Jamaica

The ANSI-ASQ National Accreditation Board is pleased to announce that the following certification body has earned ANAB accreditation for ISO 14001:

Bureau of Standards Jamaica d.b.a. National Certification Body of Jamaica
6 Winchester Road
Kingston 10, Jamaica
Marcia Cohen
PHONE: (876) 926-3140

International Organization for Standardization (ISO)

ISO Call for US/TAG Administrator

ISO/TC 215 – Health informatics

ANSI has been informed that HIMSS, the ANSI-accredited US/TAG administrator for ISO/TC 215, wishes to relinquish the role as US/TAG administrator. ISO/TC 215 has the following scope:

Standardization in the field of information for health, and Health Information and Communications Technology (ICT) to achieve compatibility and interoperability between independent systems. Also, to ensure compatibility of data for comparative statistical purposes (e.g. classifications), and to reduce duplication of effort and redundancies.

Organizations interested in serving as the US/TAG administrator should contact Audrey Dickerson at adickerson@himss.org.

International (ISO) Secretariat

ISO/TC 215 – Health informatics

ANSI has been informed that HIMSS, the ANSI-delegated Secretariat of ISO/TC 215, wishes to relinquish the role of delegated secretariat. It is the intent of the US/TAG to ISO/TC 215 that the ISO/TC 215 secretariat be retained in the United States. Organizations interested in assuming the role of ANSI-delegated secretariat should contact ANSI, using the below contact information, no later than June 6, 2010.

The scope of ISO/TC 215 is as follows:

Standardization in the field of information for health, and Health Information and Communications Technology (ICT) to achieve compatibility and interoperability between independent systems. Also, to ensure compatibility of data for comparative statistical purposes (e.g. classifications), and to reduce duplication of effort and redundancies.

Information concerning the role and responsibilities of an ANSI-delegated ISO international technical committee secretariat may be obtained by contacting Rachel Howenstine at isot@ansi.org.

ISO Proposals for New Fields of ISO Technical Activity

Nutrition and Dietetics

Comment Deadline: July 2, 2010

KEBS (Kenya) has submitted to ISO a new work item proposal for the development of an ISO standard on Nutrition and Dietetics with the following scope:

Standardization in the field of nutrition and dietetics services, covering intervention programs, nutritional clinical practice, nutrition in emergency response, as well as preparation and serving of institutional and household foods, in particular, but not limited to terminology, nutrition assessment tools and methods, food measurements, and criteria for nutrition supplements, advertisements and promotions, and training in nutrition and dietetics.

Anyone wishing to review the new work item proposal can request a copy of the proposal by contacting ANSI's ISO Team via email: isot@ansi.org with a submission of comments to Steve Cornish (scornish@ansi.org) by July 2, 2010.

General Technical Rules for Determination of Energy Savings in Renovation Projects, Industrial Enterprises and Regions

Comment Deadline: July 2, 2010

SAC (China) has submitted to ISO a new work item proposal for the development of an ISO standard on General technical rules for determination of energy savings in renovation projects, industrial enterprises and regions with the following scope:

- Standardization of the general technical rules for measurement, calculation and verification of energy savings in renovation projects, industrial enterprises and regions.
- The standard specifies the general technical rules for measurement, calculation and verification of energy savings applicable in energy efficient renovation projects on existing or new building facilities, industrial utilities and processes.
- It also specifies the general technical rules for measurement, calculation and verification of energy savings of industrial enterprises. It can be used in evaluating energy efficient activities of industrial enterprises in voluntary or mandatory mechanisms. It may reduce the technical barriers in energy savings trade such as energy performance contracting.
- Finally, it is also applicable to determine the energy savings of regions which implementing energy efficient policies and measures, such as mandatory standards, tax rebates, subsidy programs, propagation programs and so on.

Anyone wishing to review the new work item proposal can request a copy of the proposal by contacting ANSI's ISO Team via email: isot@ansi.org with a submission of comments to Steve Cornish (scornish@ansi.org) by July 2, 2010.

International Electrotechnical Commission (IEC)

IEEE Requests Assignment as Administrative Secretariat of IEC/TC 106 – Methods for the Assessment of Electric, Magnetic and Electromagnetic Fields Associated with Human Exposure

The Canadian National Committee for IEC has announced that it is relinquishing the Secretariat of IEC/TC 106 - Methods for the assessment of electric, magnetic and electromagnetic fields associated with human exposure. The National Committees of IEC have been invited to submit requests for this assignment by the IEC Standardization Management Board. The Institute of Electrical and Electronics Engineers (IEEE) has requested the USNC/IEC to ask the SMB for this assignment and to assign IEEE as Administrative Secretariat for the activity.

Scope:

To prepare international standards on measurement and calculation methods to assess human exposure to electric, magnetic and electromagnetic fields. The task includes:

- characterization of the electromagnetic environments with regard to human exposure;
- measurement methods, instrumentation and procedures;
- calculation methods;
- assessment methods for the exposure produced by specific sources (in so far as this task is not carried out by specific product committees);
- basic standards for other sources;
- assessment of uncertainties.

It covers the whole frequency range from 0 Hz to 300 GHz. It applies to basic restrictions and reference levels.

Excluded are:

- the establishment of exposure limits;
- mitigation methods which have to be dealt with by the relevant product committees.

The USNC Technical Management Committee has the responsibility for delegating Administrative Secretariat responsibility for this TC if the USNC is assigned this Secretariat responsibility by the IEC SMB. The assigned Administrative Secretariat is responsible for nominating a Secretary to carry out the administrative work of the TC and for supporting this work for a 4 year period. The purpose of this notification is to determine if there are any objections to this assignment to IEEE by the USNC TMC. Such objections should be made known as soon as possible to:

Charles T Zegers
 General Secretary, USNC/IEC
 American National Standards Institute
 25 West 43rd Street, 4th Floor
 New York, NY 10036
 PHONE: (212) 642-4965
 FAX: (212) 730 1346
 E-Mail: czegers@ansi.org

If no objections are raised the USNC TMC will be asked to consider requesting assignment of the Secretariat of IEC/TC 106 from the IEC/SMB and the assignment of IEEE as the Administrative Secretariat of this IEC Technical Committee.

U.S. Technical Advisory Groups

Expansion of TAG Scope

U.S. Technical Advisory Group (TAG) to ISO/PC 243 – Consumer Product Safety

Comment Deadline: June 21, 2010

Underwriters Laboratories (UL), in its role as the TAG Administrator of the currently accredited U.S. Technical Advisory Group (TAG) to ISO Project Committee 243, Consumer Product Safety, has requested the expansion of the TAG's scope to cover the activities of ISO Project Committee 240, Product Recall. The currently accredited U.S. TAG to ISO/PC 243 has adopted the Model Operating Procedures for U.S. TAGs to ANSI for ISO Activities, as contained in Annex A of the ANSI International Procedures. Please forward any comments on this action by June 21, 2010 to: Mr. Mitchell Gold, Standards Coordinator, Underwriters Laboratories, 333 Pfingsten Road, Northbrook, IL 60062-2096; PHONE: (847) 664-2850; FAX: (847) 313-2850; E-mail: mitchell.gold@us.ul.com (please copy jthomps@ansi.org).

Call for Members

US TAG for ISO PC 243 – Consumer Product Safety

Mr. Mitchell Gold of Underwriters Laboratories serves as the TAG Administrator for the US TAG for ISO PC 243. He has advised that they are in the process of creating a US TAG to provide input into ISO PC 243 that is developing a Guidance Standard – Consumer Product Safety: A Practical Guide for Suppliers. As a result, the TAG Administrator is looking for members interested in this work. In addition, a request has been made by the TAG Administrator to ANSI to expand the scope of the TAG to include ISO PC 240 Product Recall. ISO PC 240 is in the process of developing a Guidance Standard on Product Recall and Corrective Actions.

Scope: To prepare an international standard on Consumer Product Safety: A Practical Guide for Suppliers that will provide assistance to suppliers in identifying, assessing and eliminating hazards and reducing risks associated with consumer products.

Anyone interested in participating should contact: Mitchell Gold, ISO PC Secretary, Underwriters Laboratories, Standards Department, PHONE: 1-847-664-2850, FAX: 1-847-313-2850, E-Mail: Mitchell.Gold@us.ul.com.

Tracking number 245i4r1
 © NSF International 2010

Proposed revision to NSF/ANSI 245-2007
 Issue 4, Draft 1 (May 2010)

This document is part of the NSF International Standards process and is for NSF Committee use only. It shall not be reproduced, or circulated, or quoted, in whole or in part, outside of NSF activities, except with the approval of NSF.

-
-
-

8.3.3 Analyses

The samples collected as described in 8.3.1 and 8.3.2 shall be analyzed as follows:

Parameter	Sample type	Sample location		
		Raw influent	Treated effluent	Testing location
BOD ₅	24 h composite	X		Laboratory
CBOD ₅	24 h composite		X	Laboratory
Total suspended solids	24 h composite	X	X	Laboratory
PH	Grab	X	X	Test site
Temperature (°C)	Grab	X	X	Test site
Dissolved oxygen	Grab		X	Test site
Alkalinity (as CaCO ₃)	24 h composite	X	X	Laboratory
TKN (as N)	24 h composite	X	X	Laboratory
Ammonia-N (as N)	24 h composite	X	X	Laboratory
Nitrite/nitrate-N (as N)	24 h composite	X	X	Laboratory

-
-
-

BSR/UL 1685

5.5.2 The burner is to be mounted on a stand and positioned on the side of the tray in which the tray rungs are attached (see Figure 5.3). The burner is to have its flame-producing surface (face) vertical and its long dimension horizontal. The 10-1/8-inch (257-mm) dimension of the array of holes is to be spaced 3 inches (76 mm) from the cables in the tray and is to be centered midway between the side rails of the tray. The centerpoint of the burner face is to be positioned 18 inches (457 mm) above the bottom end of the tray and cables and midway between two tray rungs.

16.2.2 The burner is to be ignited and the gas flows are to be adjusted to the values indicated in 13.9.1 and 13.9.2. The burner is to be positioned at an angle of 20° and 3.0 ±0.2 inches (75 ±5 mm) from the nearest cable surface. See Figures 5.3 or 13.1, as applicable, for the relative positions of the cable tray and burner in the room.

Figure 5.3 (NEW)
Cable tray, specimen, and burner details for UL Flame exposure

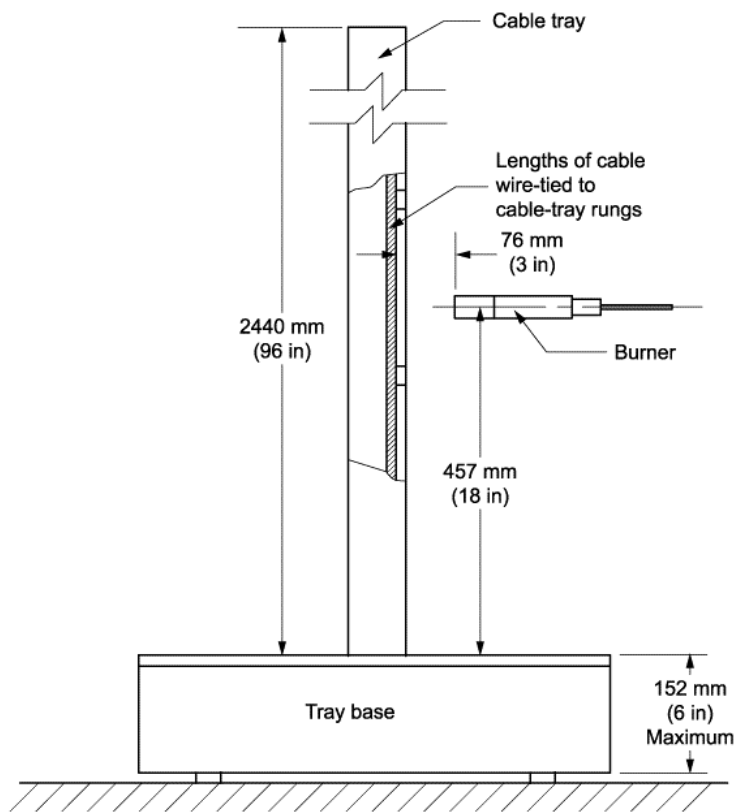

su0736

Figure 13.1 (PROPOSED)
Cable tray, specimen, and burner details for FT4/IEEE 1202 type flame exposure

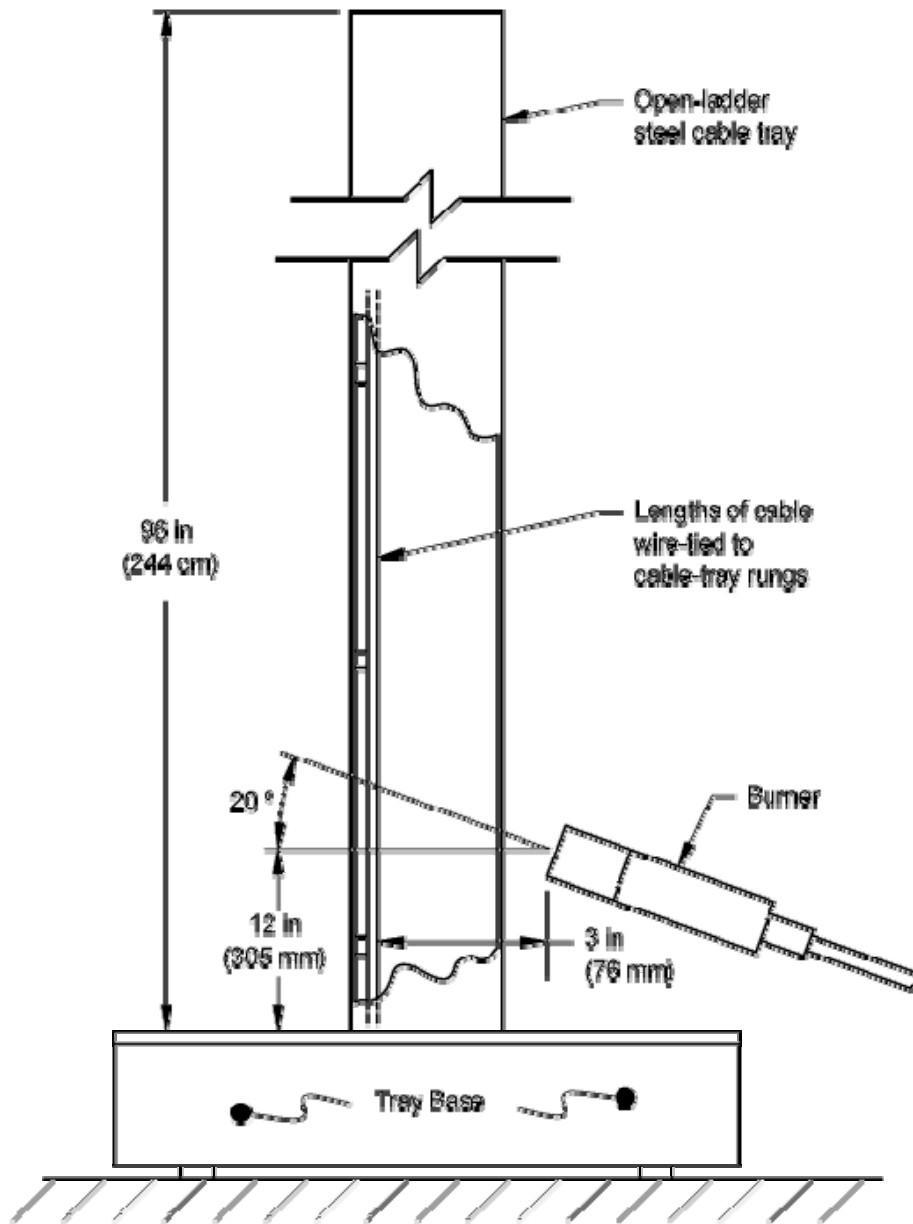

su0627

NOTES -

Cable tray - Nominally 12 inches wide by 3 inches deep by 96 inches long (305 mm x 76 mm x 244 cm) with steel rungs nominally $1 \pm 1/4$ inches wide (25 ± 6 mm) and spaced 9 inches (229 mm) on centers.

Burner - 10-inches wide (254-mm) ribbon-type burner with an air/gas venturi mixer.

Tray Base - Optional. 6 inches (152 mm) maximum height.